

Aerating Fountain - Decorative Line

Function

Our Aerating fountains or surface spray aerators are engineered to provide a unique mixed flow pumping system which delivers aeration where it is needed. Featuring eight patterns that are built upon staged pumping chambers, The decorative line is ideal for those desiring a 'fountain-like' display with additional benefit of aeration.

Features:

- Complete package consist of Aerator unit and Cable with cable quick disconnect.
- Shallow operating depth (min. depth) 75cm of water.
- CE, ETI & ETL-C certified
- Optional LED light available - Fountain Glo LED Light.
- Introduce oxygen into water to control Algae, Weeds and Odors.

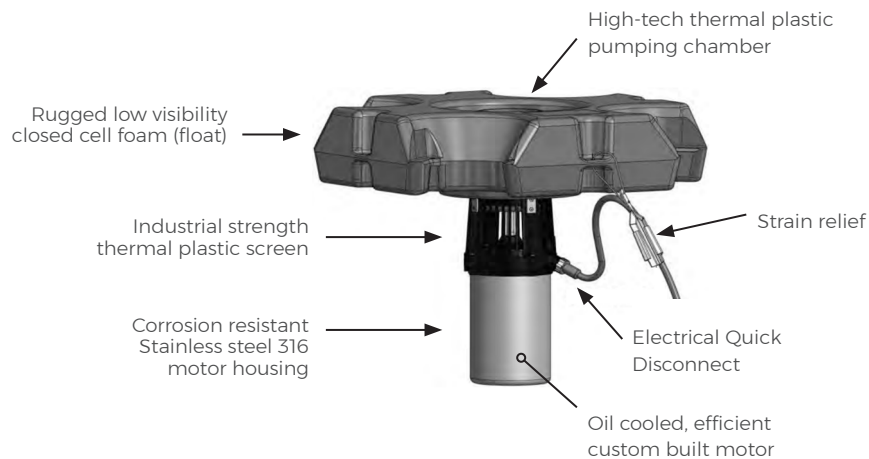

Tristar



Power	1 HP	2HP	3HP	4HP
Spray Height (m)	3	4	4.6	4.6
Spray Diameter (m)	4	5.2	6.1	6.1
Pumping Rate (m ³ /hr)	32.4	45.3	59.3	59.3
Voltage (V)	230	230	230	400
Phase	1	1	1	3
Amp	8.3	12.6	13.5	4
RPM @ Frequency	2875rpm @50Hz	2875rpm @50Hz	2875rpm @50Hz	2875rpm @50Hz
LED lighting (optional)	4	4	4	4

Aerating Fountain	Decorative Line		Rev. 0	
<p>The information contained in this drawing is the sole property of Aquashi. Any reproduction in part or as a whole without the written permission of Aquashi is prohibited. Aquashi reserves the right to update all designs, specifications and data sheets without prior notice.</p>				

Aerating Fountain - Decorative Line

Pheonix



Power	1 HP	2HP	3HP	4HP	
Spray Height (m)	3	4	4.2	4.2	
Spray Diameter (m)	5.5	6.4	7.2	7.2	
Pumping Rate (m ³ /hr)	32.4	45.3	59.3	59.3	
Voltage (V)	230	230	230	400	400
Phase	1	1	1	3	3
Amp	8.3	12.6	13.5	4	4
RPM @ Frequency	2875rpm @50Hz	2875rpm @50Hz	2875rpm @50Hz	2875rpm @50Hz	2875rpm @50Hz
LED lighting (optional)	4	4	6	6	

Rocket



Power	1 HP	2HP	3HP	4HP	
Spray Height (m)	3.8 - 4.4	4.9 - 5.5	5.6 - 6.2	5.6 - 6.2	
Spray Diameter (m)	1.5	1.5	2.4	2.4	
Pumping Rate (m ³ /hr)	23.7	33.4	43.2	43.2	
Voltage (V)	230	230	230	400	400
Phase	1	1	1	3	3
Amp	8.3	12.6	13.5	4	4
RPM @ Frequency	2875rpm @50Hz	2875rpm @50Hz	2875rpm @50Hz	2875rpm @50Hz	2875rpm @50Hz
LED lighting (optional)	4	4	6	6	

Comet



Power	1 HP	2HP	3HP	4HP	
Spray Height (m)	2.8 - 3.4	4.4 - 5	5.2 - 6.8	5.2 - 6.8	
Spray Diameter (m)	1.5	1.5	2.4	2.4	
Pumping Rate (m ³ /hr)	28	39.9	51.8	51.8	
Voltage (V)	230	230	230	400	400
Phase	1	1	1	3	3
Amp	8.3	12.6	13.5	4	4
RPM @ Frequency	2875rpm @50Hz	2875rpm @50Hz	2875rpm @50Hz	2875rpm @50Hz	2875rpm @50Hz
LED lighting (optional)	4	4	6	6	

Aerating Fountain	Decorative Line		Rev. 0	
<p>The information contained in this drawing is the sole property of Aquashi. Any reproduction in part or as a whole without the written permission of Aquashi is prohibited. Aquashi reserves the right to update all designs, specifications and data sheets without prior notice.</p>				

Aerating Fountain - Decorative Line

Equinox



Power	1 HP	2HP	3HP	4HP	
Spray Height (m)	3	4	4.5	5.3	
Spray Diameter (m)	10.5	12	17	18.3	
Pumping Rate (m ³ /hr)	32.4	45.3	59.3	59.3	
Voltage (V)	230	230	230	400	400
Phase	1	1	1	3	3
Amp	8.3	12.6	13.5	4	4
RPM @ Frequency	2875rpm @50Hz	2875rpm @50Hz	2875rpm @50Hz	2875rpm @50Hz	2875rpm @50Hz
LED lighting (optional)	6	8	8	8	8

Genesis



Power	1 HP	2HP	3HP	4HP	
Spray Height (m)	2.1	3.4	4.2	4.2	
Spray Diameter (m)	7.6	10.7	13.7	13.7	
Pumping Rate (m ³ /hr)	32.4	45.3	59.3	59.3	
Voltage (V)	230	230	230	400	400
Phase	1	1	1	3	3
Amp	8.3	12.6	13.5	4	4
RPM @ Frequency	2875rpm @50Hz	2875rpm @50Hz	2875rpm @50Hz	2875rpm @50Hz	2875rpm @50Hz
LED lighting (optional)	4	6	8	8	8

Constellation



Power	1 HP	2HP	3HP	4HP	
Spray Height (m)	1.2	1.8	2.4	2.4	
Spray Diameter (m)	5.4	7.6	9.6	9.6	
Pumping Rate (m ³ /hr)	32.4	45.3	59.3	59.3	
Voltage (V)	230	230	230	400	400
Phase	1	1	1	3	3
Amp	8.3	12.6	13.5	4	4
RPM @ Frequency	2875rpm @50Hz	2875rpm @50Hz	2875rpm @50Hz	2875rpm @50Hz	2875rpm @50Hz
LED lighting (optional)	4	4	6	6	6

Aerating Fountain	Decorative Line		Rev. 0	
<p>The information contained in this drawing is the sole property of Aquashi. Any reproduction in part or as a whole without the written permission of Aquashi is prohibited. Aquashi reserves the right to update all designs, specifications and data sheets without prior notice.</p>				

Aerating Fountain - Decorative Line

Omega



Power	1 HP	2HP	3HP	4HP
Spray Height (m)	2.7	3.1	3.5	3.5
Spray Diameter (m)	3	4.1	5	5
Pumping Rate (m ³ /hr)	32.4	45.3	59.3	59.3
Voltage (V)	230	230	230	400
Phase	1	1	1	3
Amp	8.3	12.6	13.5	4
RPM @ Frequency	2875rpm @50Hz	2875rpm @50Hz	2875rpm @50Hz	2875rpm @50Hz
LED lighting (optional)	4	4	4	4

LED Lights: (Optional)

Energy efficient low voltage LED light set available in combination of 2 to 8 lights. Sequencing option available on request.

Light Colour	Bright White	Warm White	RGBW
Power	6.5 W	6.5 W	40 W
Voltage	15V DC	15V DC	30V DC
Lumen	5700K	3000K	420/480/130/620

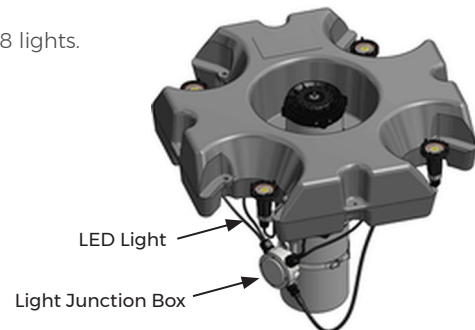

Sample installation

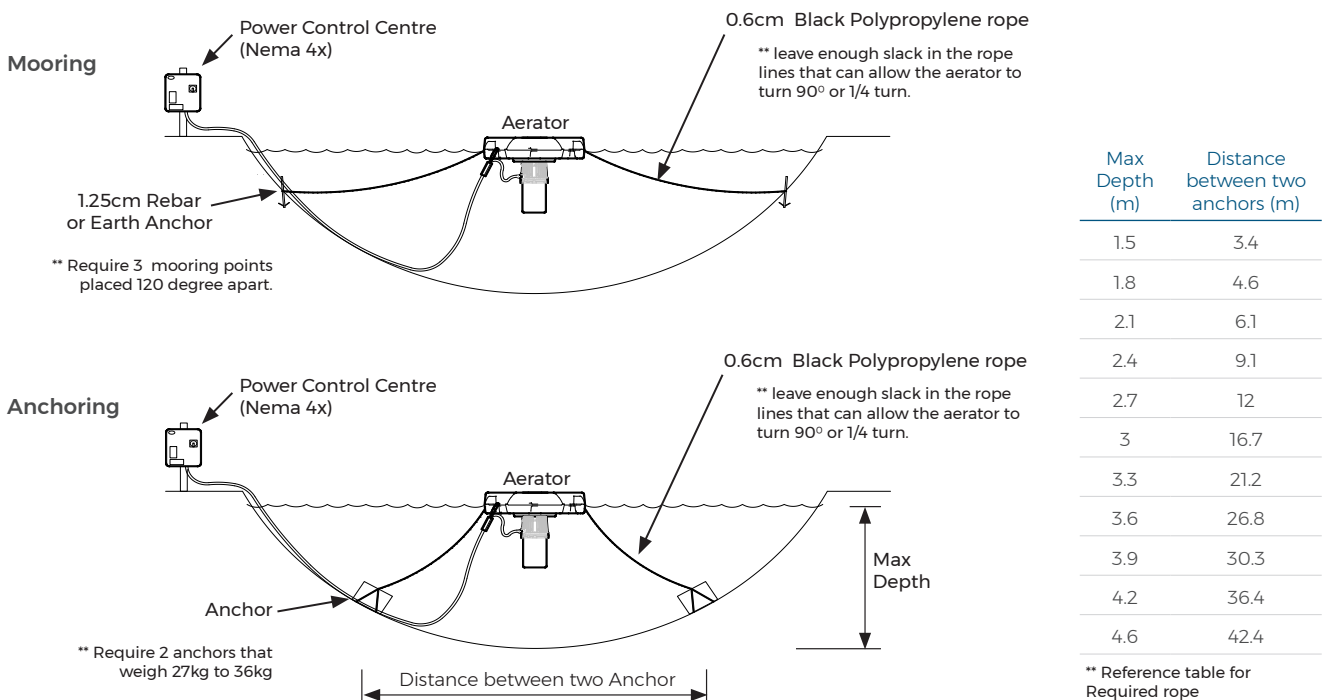

Aerating Fountain	Decorative Line	Rev. 0	
The information contained in this drawing is the sole property of Aquashi. Any reproduction in part or as a whole without the written permission of Aquashi is prohibited. Aquashi reserves the right to update all designs, specifications and data sheets without prior notice.			