

Diffused Aeration - Air Flo 3

Function

Air flo 3 is a diffused air system which provides a subsurface solution to aerating ponds and lakes while also breaking up thermal stratification. Sometimes referred to as a ‘bubbler’ system, the Air flo 3 offers quiet operation and versatility in managing ponds and lakes while requiring little to no maintenance. Although this product can be used in most water depths, it is best for ponds and lakes with depths of 2.4 meters or greater.

Features:

- Complete package consist of Compressor(s), Cabinet and diffuser(s). Tubing sold separately.
- Maximum depth 12 meters.
- CE, ETI & ETL-C certified
- Run by 1/2HP oil-less rocking piston Compressor, Housed in a Compact low profile cabinet 41cm x 41cm x 52cm with axial fan.
- Ø350mm Self cleaning diffuser manifold disk



Model No.	Diffuser Pad(s)	Diffuser disk per System	Compressor Qty.	Voltage	Amp	Hz
AF3-121	2	2				
AF3-131	3	3				
AF3-141	4	4	Single Compressor inside a Cabinet	220V	2.8 amps	50Hz
AF3-112	1	2				
AF3-122	2	4				
AF3-241	4	4				
AF3-261	6	6				
AF3-281	8	8				
AF3-222	2	4	Two Compressor inside a Cabinet	220V	5.6 amps	50Hz
AF3-232	3	6				
AF3-242	4	8				
AF3-262	6	12				

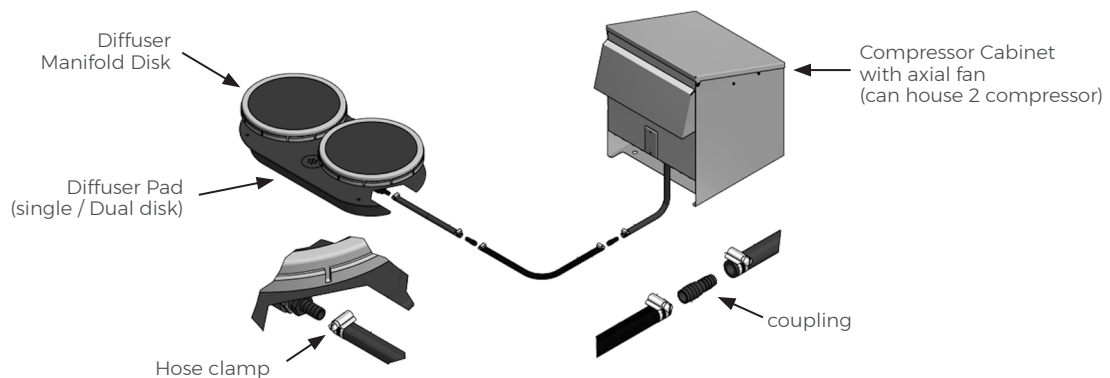

Diffused Aerator	Air flo 3		Rev. 0	
<p>The information contained in this drawing is the sole property of Aquashi. Any reproduction in part or as a whole without the written permission of Aquashi is prohibited. Aquashi reserves the right to update all designs, specifications and data sheets without prior notice.</p>				