

Anti-Entrapment Frame and Grate - DFG-AE Series

Function

Anti-Entrapment / Anti-Vortex frame and grate for use in swimming pools. Engineered for safety and designed to avoid limb entrapment.

This stainless steel grating is VGB (Virginia Graeme Baker Act) compliant when installed in a split drain design with specified sump dimensions. Refer to sample installation and sump design drawings. Drain shall be sized at maximum flow for each individual drain.



Specifications

Materials

Stainless steel 316

Shape

Square

Model No.	A (mm)	B (mm)	C (mm)	D (mm)	Recommended Max. Flow (m³/H)
DFG-AE-009	280	229	20	27	24 (0.5 m/s)
DFG-AE-012	360	305	26	27	42 (0.5 m/s)
DFG-AE-016	460	406	35	27	77 (0.5 m/s)
DFG-AE-020	560	508	47	27	130 (0.5 m/s)

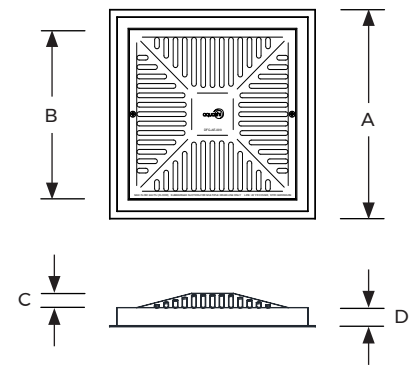

Sample Installation

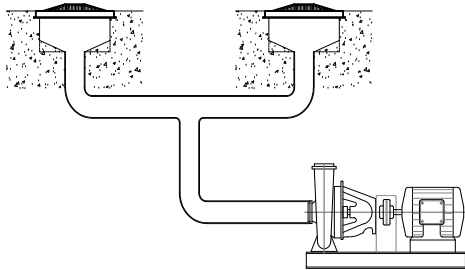

Split Drain design

1. Drains shall be paired with Max Flow in a single drain.
2. Velocity shall be less than 0.5 s/m.
3. Suction piping shall be balanced and sized accordingly.
4. Distance between 2 drains should be 2 meters or more.
5. Flow rate per cover is equal to Total system flow divided by number of drains in the system minus 1.

$$\text{Flow rate per cover} = \frac{\text{Total system flow}}{(\text{Total Drain Quantity} - 1)}$$

Field Built Sump Design:

(Required to comply with VGB act)

P = Drain Pipe Size

1.5*P = Drain Pipe Size multiply by 1.5

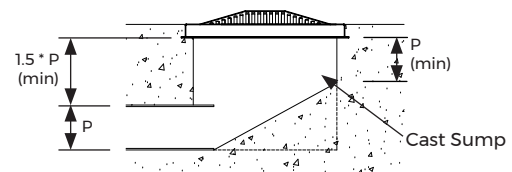
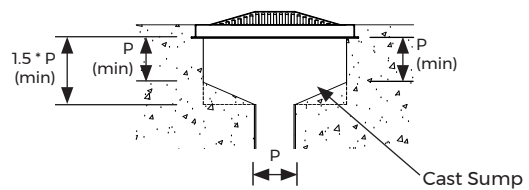

Frame and Grate	DFG-AE Series	Model No. DFG-AE	Rev. 2	
<p>The information contained in this drawing is the sole property of Aquashi. Any reproduction in part or as a whole without the written permission of Aquashi is prohibited. Aquashi reserves the right to update all designs, specifications and data sheets without prior notice.</p>				

Anti-Entrapment Frame and Grate - DFG-AE Series

Model No.

DFG-AE-009

DFG-AE-012

DFG-AE-016

DFG-AE-020

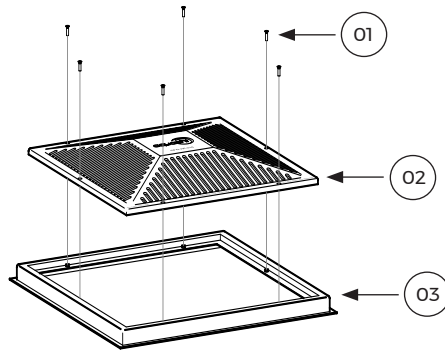



#	Part Name	Qty.
01	M4x20 Counter sunk Philips screw (Stainless steel 316)	2-6
02	Grating	1
03	Niche	1

Anti-Entrapment Frame and Grate with Sump

Model No.	Outlet (BSP)	A (mm)	B (mm)	C (mm)	D (mm)	Recommended Max. Flow (m ³ H)
DFG-AE-009-SUMP	3"	316	229	20	135	24 (0.5 m/s)
DFG-AE-012-SUMP	4"	392	305	26	165	42 (0.5 m/s)
DFG-AE-016-SUMP	6"	493	406	35	240	77 (0.5 m/s)
DFG-AE-020-SUMP	8"	595	508	47	338	130 (0.5 m/s)

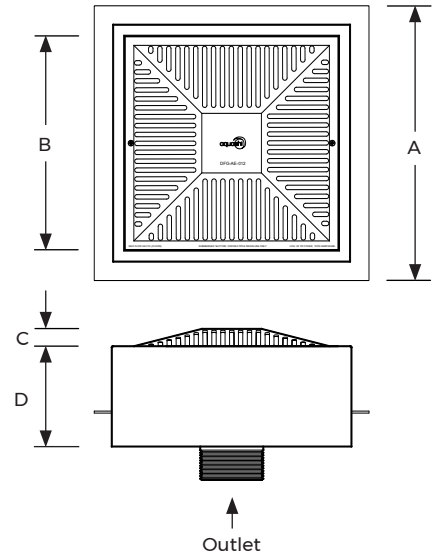
* Custom Sump outlet direction available on request.



Frame and Grate	DFG-AE Series	Model No. DFG-AE	Rev. 2	
<p>The information contained in this drawing is the sole property of Aquashi. Any reproduction in part or as a whole without the written permission of Aquashi is prohibited. Aquashi reserves the right to update all designs, specifications and data sheets without prior notice.</p>				