

Deck Jet Nozzle - DJN-S Series

Function

Designed for walkable in-concrete deck installation. The Deck jet nozzle is available in Geyser, Column or Sparkle spray effect. Each nozzle is removable from its body using the nozzle key for maintenance.

Specifications

Materials

Stainless steel 316

Connection type

1" BSP Female thread

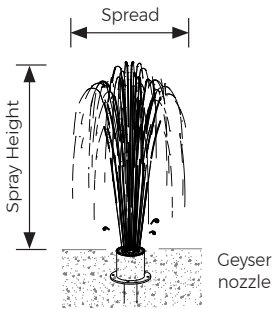
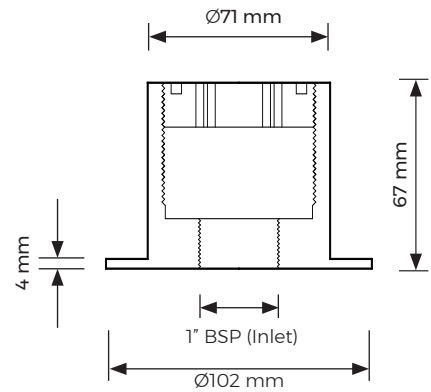

Model No.	Description	Spray Height (m)	0.5	1	1.5	2
DJN-S100-CYR	Geyser Deck fountain nozzle	Flow (LPM)	24.2	34.1	41.25	47.3
		Head (m)	1.1	2.8	3.5	4.8
		Spread (m)	0.2	0.4	0.8	1.1

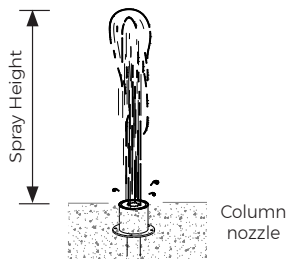

Model No.	Description	Spray Height (m)	0.5	1	1.5	2	2.5
DJN-S100-CLM	Column Deck fountain nozzle	Flow (LPM)	39.6	53.9	66	77	88
		Spread (m)	2.4	5.4	8.4	11	13.8

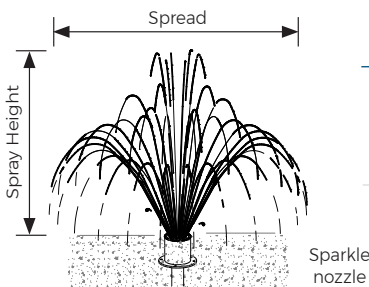

Model No.	Description	Spray Height (m)	0.3	0.6	0.9	1.2	1.5
DJN-S100-SPK	Sparkle Deck fountain nozzle	Flow (LPM)	63	86	105	119	135
		Head (m)	0.3	0.7	1	1.3	1.7
		Spread (m)	0.5	1	1.5	2	2.5

Deck Jet Nozzle	DJN-S Series	Model No. DJN-S	Rev. 1	
<p>The information contained in this drawing is the sole property of Aquashi. Any reproduction in part or as a whole without the written permission of Aquashi is prohibited. Aquashi reserves the right to update all designs, specifications and data sheets without prior notice.</p>				