

# Slab Hanger Drain - SHD Series

## Function

Designed as a walkable drain for use in dry deck fountains, the slab hanger drain provides outlets to drain water back into the pond beneath it or reservoir tank. Two adjustable bottom clamps enables the installer to secure the drain to the stone slab. Supplied with optional flush mounted screw holes for niched concrete installation.



## Specifications

### Materials

Stainless steel 316

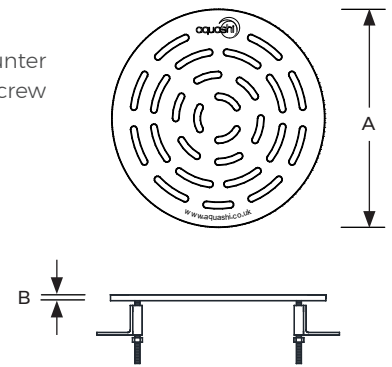
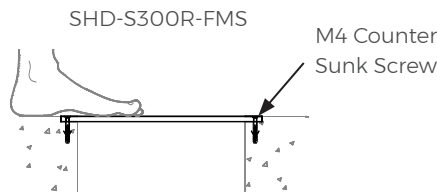
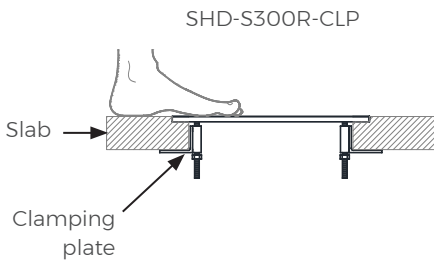

Model No.	Description	Shape	A (mm)	B (mm)
SHD-S300R-CLP	Round Slab hanger drain with Slab Clamp	Round	300	8
SHD-S300R-FMS	Round Slab hanger drain with Flush mounted screw	Round	300	8

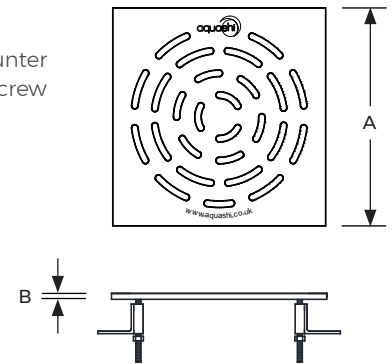
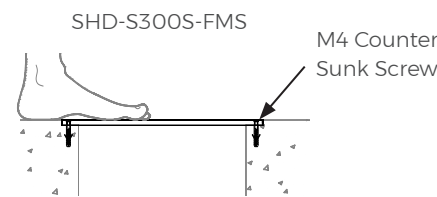
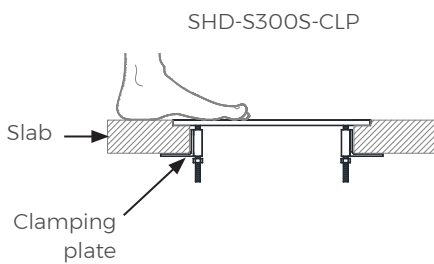

Model No.	Description	Shape	A (mm)	B (mm)
SHD-S300S-CLP	Square Slab hanger drain with Slab Clamp	Square	300	8
SHD-S300S-FMS	Square Slab hanger drain with Flush mounted screw	Square	300	8

Slab Hanger Drain	SHD Series	Model No. SHD	Rev. 0	
<p>The information contained in this drawing is the sole property of Aquashi. Any reproduction in part or as a whole without the written permission of Aquashi is prohibited. Aquashi reserves the right to update all designs, specifications and data sheets without prior notice.</p>				